

Acme Pumps

Type ES & SES Single-Stage
End-Suction Centrifugal Pumps

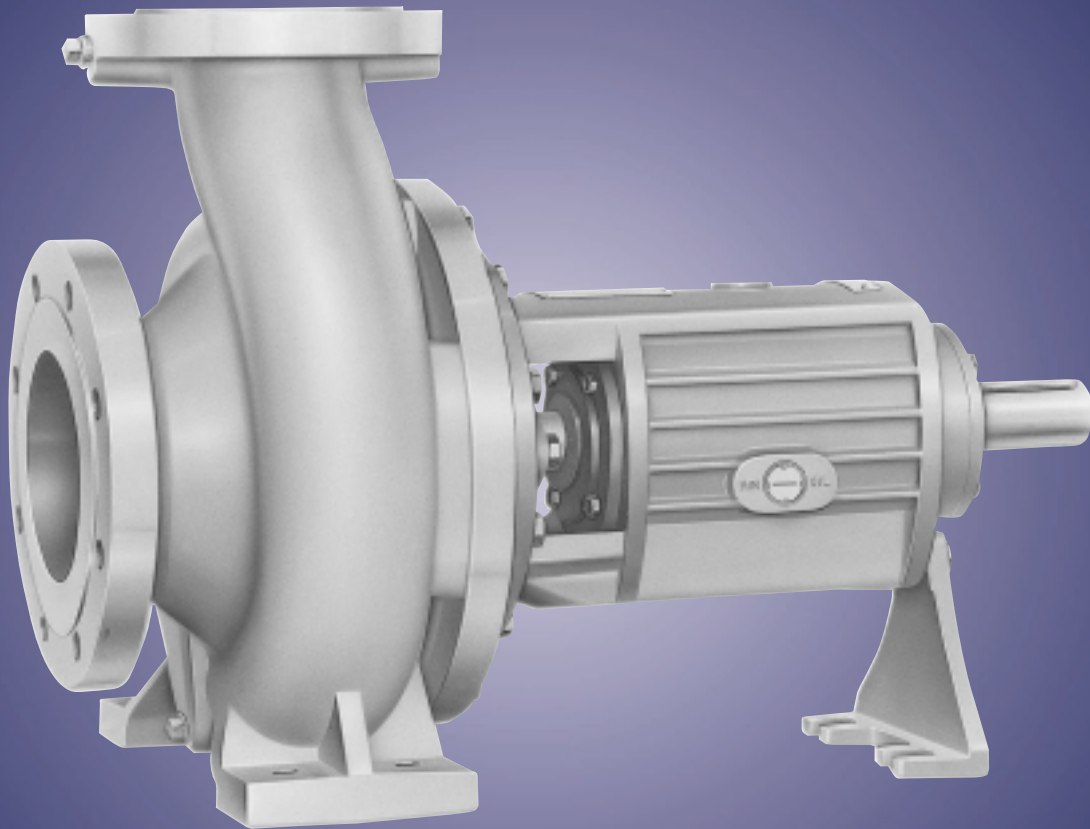

ISO 2858 • 16 bar working pressure • Back-pull-out Construction • Heavy-duty angular-contact ball bearings

Description

ACME type ES and SES centrifugal pumps are of single-stage end-suction design, and are especially suitable for handling water, chemicals and corrosive liquids. They are available in cast iron and a range of corrosion resistant materials suitable for use in the food, chemical and waste industries, as well as in general industrial applications where corrosion resistance is required. More importantly, ACME ES and SES centrifugal pumps are designed to ensure a long, continuous service life at an efficient cost.

Features

- **ISO 2858 standard** to ensure dimensional interchangeability with other pumps of the same standard.
- **Designed for 16 bar working pressure** with optional casing for a working pressure of up to 20 bar. A robust and solid construction that guarantees long life even under high suction pressure conditions.
- **More than 3mm corrosion allowance** for extended use on corrosive applications.
- **Back-pull-out construction** allows rotating assembly to be withdrawn without disturbing the suction and delivery connections.
- **Double volute design** available for selected pumps. It eliminates radial load by balancing the hydraulic force of the liquid within the pump casing, extends seal and bearing life and minimizes vibration and noise.
- **DIN 2533 ND/16** suction and delivery flanges connections to meet the design working pressure rating.
- **Heavy-duty, deep-grooved bearings** with minimum 50,000 hours operating life under normal condition.
- **Grease lubricated** sealed-for-life bearings require no maintenance.
- **Heavy-duty, stiff solid shaft design** with low L3/D4 ratio ensures less than 0.05mm shaft deflection at the seal face in all operating conditions. This extends the seal life.
- **Seal housing** is constructed to accommodate different seal designs, so as to meet the severe heavy-duty requirements.
- **Excellent parts interchangeability** reduces inventory levels for spare parts to a minimum.

Optional Features

- **Heavy-duty, oil lubricated angular-contact ball bearings** with a minimum of 50,000 hours operating life ensure long life and reliability.
- **Labyrinth seal** can be fitted to seal out water or other harmful contaminants.
- **Oil temperature indicator** is available to indicate oil temperature.
- **Stuffing box cooling** is available to meet the high temperature service requirements.
- **Bearing housing cooling** is available for pumping liquids above 110 °C.

Construction

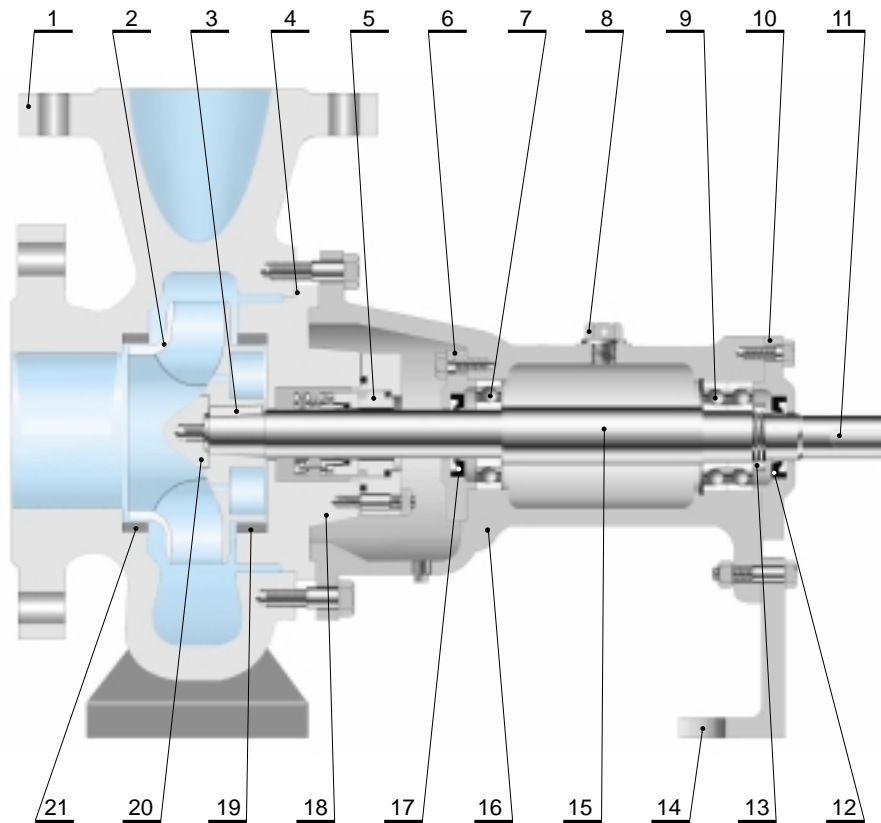

- | | | |
|----------------------|--|-------------------------------|
| 1 Pump Casing | 8 Breath Valve (optional) | 15 Shaft |
| 2 Impeller | 9 Double Row Thrust Bearing (optional) | 16 Bearing Bracket |
| 3 Impeller Key | 10 Thrust Bearing Cover | 17 Oil Seal |
| 4 Casing Joint | 11 Coupling Key | 18 Stuffing Box Cover |
| 5 Mechanical Seal | 12 Oil Seal | 19 Back Wear Ring (optional) |
| 6 Line Bearing Cover | 13 Bearing Locknut | 20 Impeller Nut |
| 7 Line Bearing | 14 Bearing Bracket Foot | 21 Front Wear Ring (optional) |

Material Specifications

Parts	Casing	Impeller	Shaft	Impeller Nut	Bearing Frame
MATERIALS	Cast Iron	Bronze	416 SS	416 SS	C.I. or D.I.
	Cast Iron	316 SS	416 SS	316 SS	C.I. or D.I.
	316 SS	316 SS	Duplex SS	316 SS	C.I. or D.I.
	Duplex SS	Duplex SS	Duplex SS	Duplex SS	C.I. or D.I.
	Hastelloy	Hastelloy	Hastelloy	Hastelloy	C.I. or D.I.
	Alloy 20	Alloy 20	Alloy 20	Alloy 20	C.I. or D.I.
	Titanium	Titanium	Titanium	Titanium	C.I. or D.I.
	Monel	Monel	Monel	Monel	C.I. or D.I.

* Other materials include Zirconium, Incoloy, Inconel and other Nickel Alloys

Operating Limits

	Working Pressure	Test Pressure	Suction Pressure	Max. Liquid Temperature
Standard Option	16 bars	24 bars	Up to 16 bars	110° C without cooling
	20 bars	30 bars	Up to 16 bars	250° C with cooling

Coverage Charts – 50 Hz

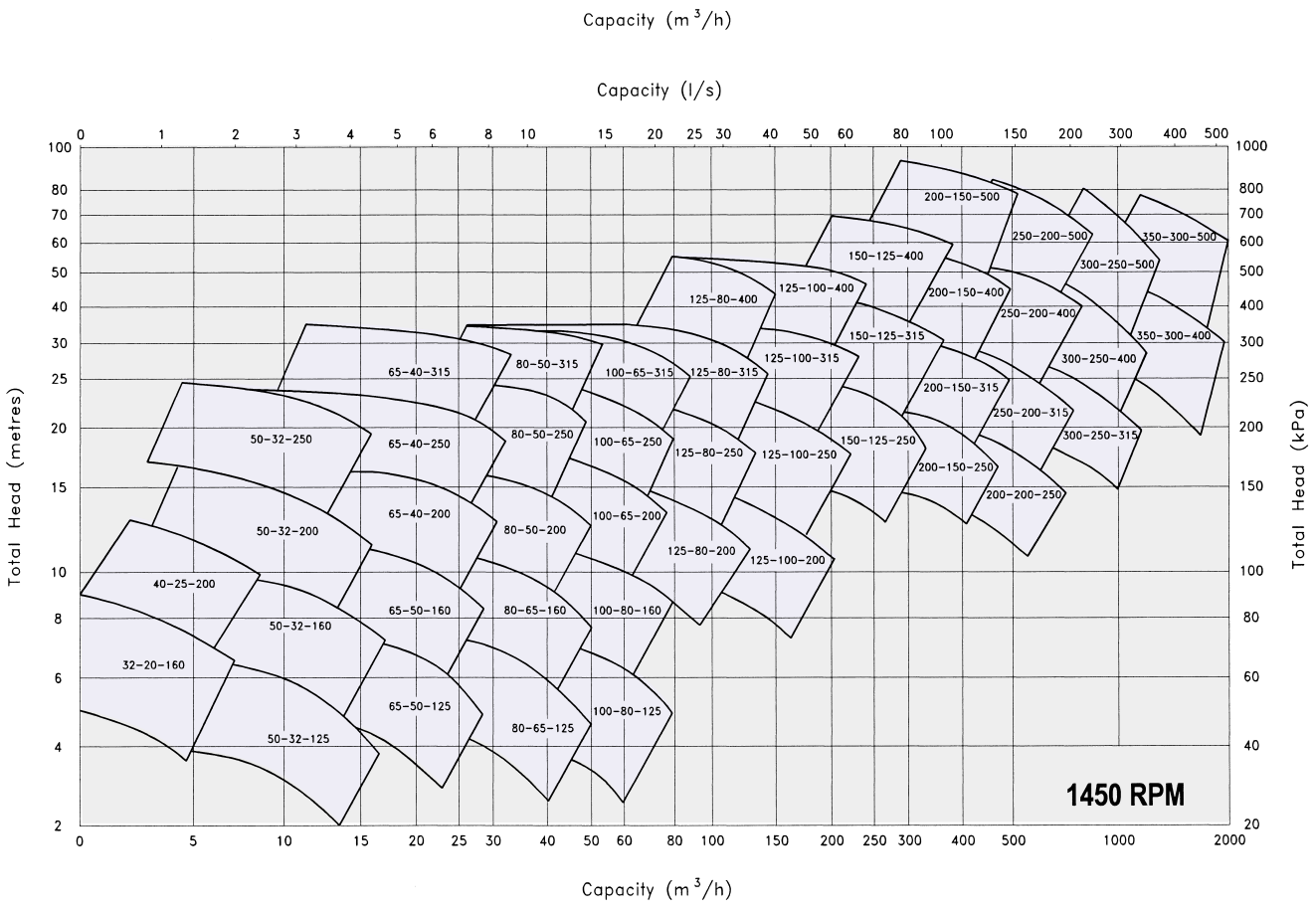
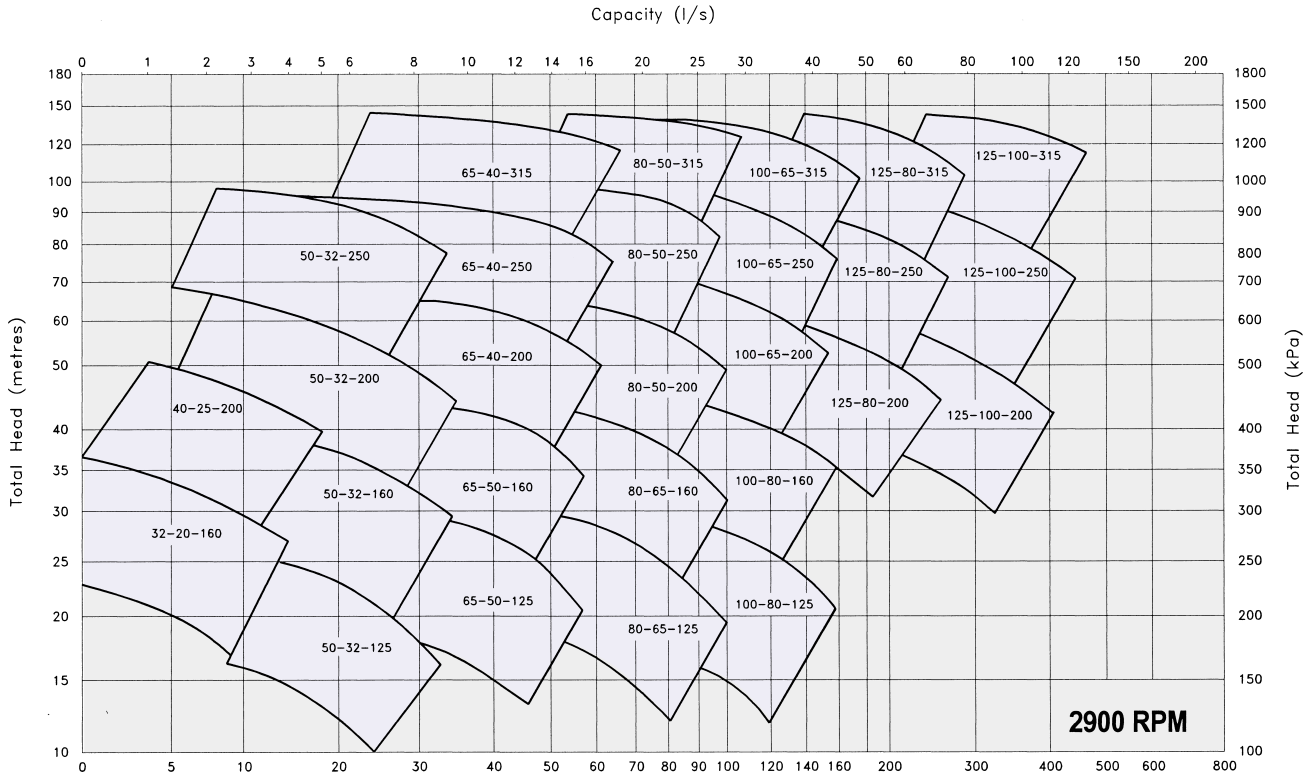

Coverage Charts – 60 Hz

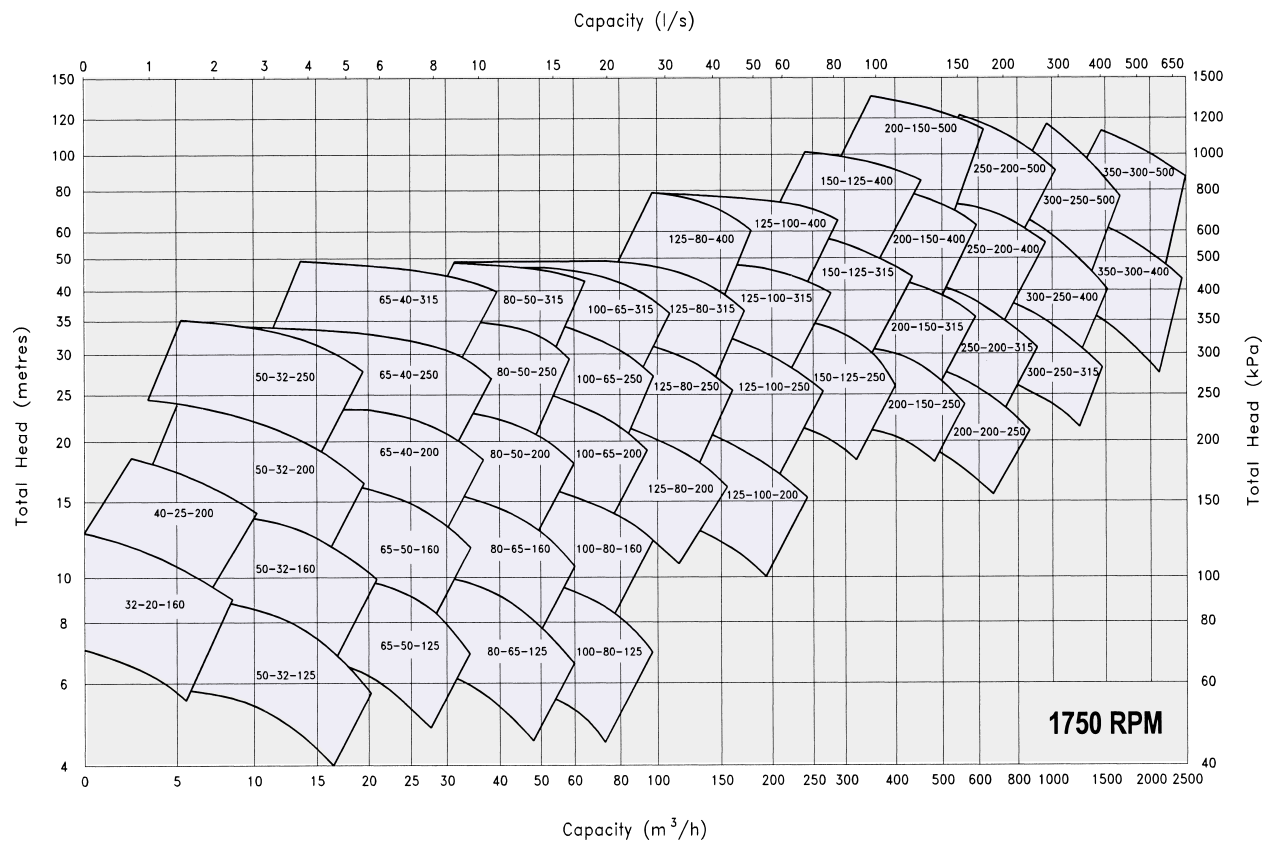
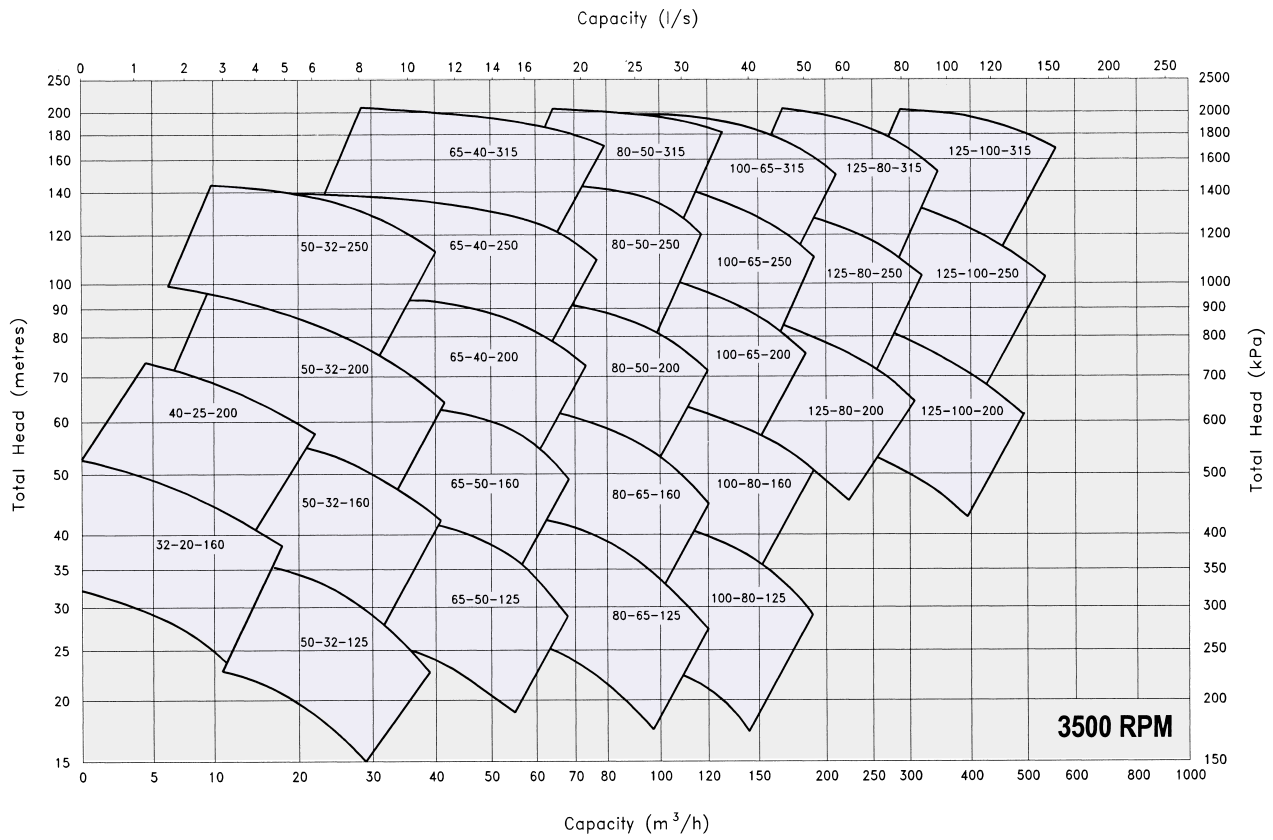

Dimensions

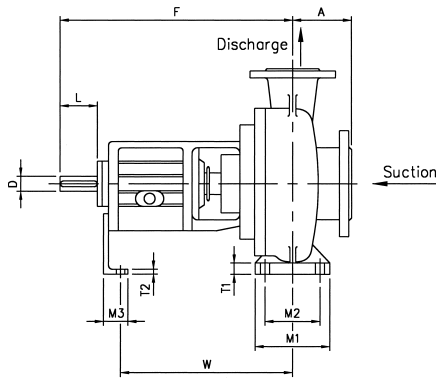

All dimensions are in mm unless otherwise stated
Standard flanges rating is PN 16

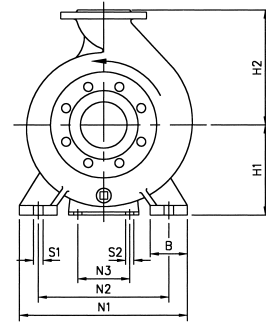

Pump Size	Diameter		Frame Size	Pump Dimensions				Mounting Dimensions										DIA.		Shaft	
	Suc.	Dis.		A	F	H1	H2	B	M1	M2	M3	N1	N2	N3	T1	T2	W	S1	S2	D	L
50-32-125	50	32	1	80	385	112	140	50	100	70	54	190	140	110	14	6	285	14.5	14.5	24	50
65-50-125	65	50	1	80	385	112	140	50	100	70	54	210	160	110	14	6	285	14.5	14.5	24	50
80-65-125	80	65	1	100	385	132	175	50	100	70	54	265	212	110	16	6	285	14.5	14.5	24	50
100-80-125	100	80	1	100	385	160	190	65	125	95	54	280	212	110	16	6	285	14.5	14.5	24	50
32-20-160	32	20	0	80	385	132	160	50	100	70	54	240	190	110	14	6	285	14.5	14.5	20	45
50-32-160	50	32	1	80	385	132	160	50	100	70	54	240	190	110	14	6	285	14.5	14.5	24	50
65-50-160	65	50	1	80	385	132	160	50	100	70	54	240	190	110	16	6	285	14.5	14.5	24	50
80-65-160	80	65	1	100	385	160	180	50	100	70	54	265	212	110	16	6	285	14.5	14.5	24	50
100-80-160	100	80	2	100	500	160	205	65	125	95	54	280	212	110	20	6	370	14.5	14.5	32	80
40-25-200	40	25	0	80	385	160	180	50	100	70	54	240	190	110	16	6	285	14.5	14.5	20	45
50-32-200	50	32	1	80	385	160	180	50	100	70	54	240	190	110	16	6	285	14.5	14.5	24	50
65-40-200	65	40	1	100	385	160	180	50	100	70	54	265	212	110	16	6	285	14.5	14.5	24	50
80-50-200	80	50	1	100	385	160	200	50	100	70	54	265	212	110	18	6	285	14.5	14.5	24	50
100-65-200	100	65	2	100	500	180	225	65	125	95	54	320	250	110	20	6	370	14.5	14.5	32	80
125-80-200	125	80	2	125	500	180	250	65	125	95	54	345	280	110	20	6	370	14.5	14.5	32	80
125-100-200	125	100	2	125	500	200	280	80	160	120	54	360	280	110	20	6	370	18.5	14.5	32	80
50-32-250	50	32	2	100	500	180	225	65	125	95	54	320	250	110	20	6	370	14.5	14.5	32	80
65-40-250	65	40	2	100	500	180	225	65	125	95	54	320	250	110	20	6	370	14.5	14.5	32	80
80-50-250	80	50	2	125	500	180	245	65	125	95	54	320	250	110	20	6	370	14.5	14.5	32	80
100-65-250	100	65	2	125	500	200	250	80	160	120	54	360	280	110	20	6	370	18.5	14.5	32	80
125-80-250	125	80	2	125	500	225	280	80	160	120	54	400	315	110	22	6	370	18.5	14.5	32	80
125-100-250	125	100	3	140	530	225	280	80	160	120	54	400	315	110	22	6	370	18.5	14.5	42	110
150-125-250	150	125	3	140	530	250	355	80	160	120	54	400	315	110	25	6	370	18.5	14.5	42	110
200-150-250	200	150	3	160	530	280	375	100	200	150	54	500	400	110	25	6	370	24	14.5	42	110
200-200-250	200	200	4	180	625	315	450	100	200	150	54	550	450	140	25	6	455	24	14.5	48	110
65-40-315	65	40	2	125	500	200	250	65	125	95	54	345	300	110	20	6	370	14.5	14.5	32	80
80-50-315	80	50	2	125	500	225	280	65	125	95	54	345	280	110	20	6	370	14.5	14.5	32	80
100-65-315	100	65	3	125	530	225	280	80	160	120	54	400	315	110	25	6	370	18.5	14.5	42	110
125-80-315	125	80	3	125	530	250	315	80	160	120	54	400	315	110	25	6	370	18.5	14.5	42	110
125-100-315	125	100	3	140	530	250	345	80	160	120	54	400	315	110	25	6	370	18.5	14.5	42	110
150-125-315	150	125	3	140	530	280	355	100	200	150	54	500	400	110	25	6	370	24	14.5	42	110
200-150-315	200	150	4	160	625	315	400	100	200	150	54	550	450	110	25	6	455	24	14.5	48	110
250-200-315	250	200	4	200	625	355	450	100	200	150	54	550	450	140	25	6	455	24	14.5	48	110
300-250-315	300	250	4	250	625	400	550	120	240	180	54	680	580	140	25	6	455	27	14.5	48	110
125-80-400	125	80	3	125	530	280	355	80	160	120	54	435	355	110	25	6	370	18.5	14.5	42	110
125-100-400	125	100	3	140	530	280	375	100	200	150	54	500	400	110	25	6	370	24	14.5	42	110
150-125-400	150	125	3	140	530	315	400	100	200	150	54	500	400	110	25	6	370	24	14.5	42	110
200-150-400	200	150	4	160	625	315	450	100	200	150	54	550	450	140	25	6	455	24	14.5	48	110
250-200-400	250	200	4	180	625	355	500	100	200	150	54	550	450	140	25	6	455	24	14.5	48	110
300-250-400	300	250	5	200	700	375	550	120	240	180	54	600	500	140	30	6	500	27	14.5	60	140
350-300-400	350	300	5	240	700	450	650	140	300	200	54	700	600	140	30	6	500	27	14.5	60	140
200-150-500	200	150	4	180	625	375	500	100	200	150	54	550	450	140	25	6	455	24	14.5	48	110
250-200-500	250	200	5	200	700	400	550	100	200	150	54	650	550	140	25	6	500	27	14.5	60	140
300-250-500	300	250	5	200	700	425	620	120	240	180	54	700	600	140	30	6	500	27	14.5	60	140
350-300-500	350	300	5	250	700	450	700	140	300	200	54	850	750	140	30	6	500	27	14.5	60	140

We reserve the right to amend design without notice.